

GS 04Q01A01-01E

### OVERVIEW

The MVAdvanced MV1000/MV2000 is a portable recorder that displays real-time measured data on a color LCD and saves data on a CompactFlash memory card (CF card). It can be hooked up to network via Ethernet, which enables to inform by E-mail and to monitor on Web site as well as to transfer files by using FTP. Also, it can communicate with Modbus RTU or Modbus TCP.

The data saved on a CF card can be converted by data conversion software to MS-Excel or text format file, facilitating processing on a PC. Not only this, the Viewer software allows a PC to display waveforms on its screen and to print out waveforms.



### STANDARD SPECIFICATION

#### General Specification

##### Construction

MV1000 external dimensions:

189(W) x 177(H) x 253(D) mm

189(W) x 177(H) x 259(D)\* mm

\*In case of clamped input terminal or /PM1 option is equipped.

Battery drive model 186 mm (H)

MV1000 weight:

Approx. 3.5 kg (MV1024)\*

\*In case of clamped input terminal, without optional features.

Add approximately 1.2 kg to the battery drive model

MV2000 external dimensions:

307(W) x 273(H) x 254(D) mm

307(W) x 273(H) x 260(D)\* mm

\*In case of clamped input terminal or /PM1 option is equipped.

MV2000 weight:

Approx. 5.6 kg (MV2048)\*

\*In case of clamped input terminal, without optional features.

##### Input

Model	Model code	Number of inputs	Measurement interval	
			Normal mode	Fast sampling mode <sup>*1</sup>
MV1000	MV1004	4	125/250 ms	25 ms
	MV1008	8		
	MV1006	6		
	MV1012	12	1 <sup>1/2</sup> /2/5 s	125 ms
	MV1024	24		
MV2000	MV2008	8	125/250 ms	25 ms
	MV2010	10		
	MV2020	20		
	MV2030	30	1 <sup>1/2</sup> /2/5 s	125 ms
	MV2040	40		
	MV2048	48		

\*1 A/D integration time is fixed to 1.67 ms in case of fast sampling mode.

\*2 1 s is not available in case of A/D integration time is 100 ms.

(Points to consider when using fast sampling mode)

When using fast sampling mode (an A/D integration time of 1.67 ms) with the MVAdvanced, power supply noise and other factors may cause the measured values to fluctuate.

If this is the case, then measure using normal mode (an A/D integration time of 16.7 ms, 20 ms, or 100 ms).

Input method:

Floating unbalanced input, isolated between channels (b terminal of RTD input is common)

A/D resolution:

+/-20000 (16 bits A/D)

Measuring range, measurement accuracy, and display accuracy by input type:

Input type	Range	Measuring range	
DCV	20mV	-20.000 to 20.000 mV	
	60mV	-60.00 to 60.00 mV	
	200mV	-200.00 to 200.00 mV	
	2V	-2.0000 to 2.0000 V	
	6V	-6.000 to 6.000 V	
	1-5V	0.800 to 5.200 V	
	20V	-20.000 to 20.000 V	
TC	50V	-50.00 to 50.00 V	
	R <sup>*1</sup>	0.0 to 1760.0°C	32 to 3200°F
	S <sup>*1</sup>	0.0 to 1760.0°C	32 to 3200°F
	B <sup>*1</sup>	0.0 to 1820.0°C	32 to 3308°F
	K <sup>*1</sup>	-200.0 to 1370.0°C	-328 to 2498°F
	E <sup>*1</sup>	-200.0 to 800.0°C	-328.0 to 1472.0°F
	J <sup>*1</sup>	-200.0 to 1100.0°C	-328.0 to 2012.0°F
	T <sup>*1</sup>	-200.0 to 400.0°C	-328.0 to 752.0°F
	N <sup>*1</sup>	0.0 to 1300.0°C	32 to 2372°F
	W <sup>*2</sup>	0.0 to 2315.0°C	32 to 4199°F
	L <sup>*3</sup>	-200.0 to 900.0°C	-328.0 to 1652.0°F
U <sup>*3</sup>	-200.0 to 400.0°C	-328.0 to 752.0°F	
RTD	WRe <sup>*4</sup>	0.0 to 2400.0°C	32 to 4352°F
	Pt100 <sup>*5</sup>	-200.0 to 600.0°C	-328.0 to 1112.0°F
DI	JPt100 <sup>*5</sup>	-200.0 to 550.0°C	-328.0 to 1022.0°F
	DCV input	OFF: less than 2.4 V ON: more than 2.4 V	
	Contact input	Contact ON/OFF	

\*1 R, S, B, K, E, J, T, N: IEC584-1 (1995), DIN IEC584, JIS C 1602-1995

\*2 W: W-5% Rd/W-26% Rd (Hoskins Mfg. Co.), ASTM E988

\*3 L: Fe-CuNi, DIN43710, U: Cu-CuNi, DIN43710

\*4 WRe: W-3%Re/W-25%Re (Hoskins Mfg. Co.)

\*5 Pt100: JIS C 1604-1997, IEC 751-1995, DIN IEC751-1996, JPt100: JIS C 1604-1989, JIS C 1606-1989

Measuring current: i = 1 mA

**Display**

Display device:  
 MV1000: 5.5-inch TFT color LCD (320 x 240 dots)  
 MV2000: 10.4-inch TFT color LCD (640 x 480 dots)  
 Note: The LCD may contain some pixels that are always lighted or that never light, and variations in brightness may occur due to the characteristics of liquid crystals. Please note that these are not defects.  
 Trend display:  
 Display types:  
 Vertical, horizontal, horizontal wide, separated horizontal  
 Digital display:  
 Update rate: 1 s  
 Tag display:  
 Number of characters:  
 16 maximum  
 Message display:  
 Number of characters:  
 32 maximum  
 Historical display function:  
 Allows for the display of data stored to internal or external memory.

**Data Saving Function**

External storage media:  
 Media: CompactFlash memory card (CF card)  
 Internal memory:  
 Media: Flash memory  
 Memory size:  
 400 MB  
 Sample time:  
 Examples of internal memory sample times with the MV1012 recording only event data files for 12 measuring channels and no calculation channels. (approx.)

Save interval	125 ms	1 s	5 s	10 s	60 s
Sample time (400 MB)	18 days	148 days	2 years	4 years	24 years

Max. savable data files:  
 400 (savable display data files and event data files combined)  
 Manual save:  
 Saves data files to the internal memory manually  
 You can save all data or only selected data.  
 Auto save:  
 Save displayed data:  
 Saves data to the CF card at a set interval  
 Save event data:  
 Saves data to the CF card at a set interval (in Free Trigger mode)  
 Save when finished sampling (when setting the trigger)  
 Data formats:  
 When saving to external media, both event data and display data can be saved in either binary or text format (data is always stored to internal memory in binary format).  
 Event data sampling period:  
 MV1004/MV1008/MV2008:  
 Selectable from 25, 125, 250, 500 ms, 1, 2, 5, 10, 30, 60, 120, 300, 600 s  
 MV1006/MV1012/MV1024/MV2010/MV2020/MV2030/MV2040/MV2048:  
 Selectable from 125, 250 ms, 1, 2, 5, 10, 30, 60, 120, 300, 600 s

Trigger function:  
 Data can be saved using Free mode or Trigger mode.  
 When using Trigger mode, the user must set the data length, pre-trigger, and trigger source.  
 Snapshot function:  
 Saves the displayed screen image data to a CF card.  
 Data file loading:  
 Data files saved to a CF card or to USB memory can be loaded and displayed.  
 Loading and saving setup data:  
 Settings data can be saved and loaded in binary format.

**Alarm functions**

Number of alarm levels:  
 Up to 4 levels for each channel  
 Alarm types:  
 High/low limit, delay high/low limit, difference high/low limit, high/low limit on rate of change  
 Display:  
 When an alarm occurs, the state (the alarm type) or common alarm state appears on the digital display

**Security features**

Description:  
 You can customize key lock and login security functions for any transmission or key command.  
 Key Lock:  
 Sets a password-protected key lock on all command keys and FUNC screen operations.  
 Login:  
 Limits access to the MVAdvanced with a login that prompts for username and password.

**Communication features (Ethernet)**

Electrical specifications:  
 IEEE 802.3 compliant (DIX frame)  
 Transmission media:  
 Ethernet (10BASE-T)  
 Protocols: TCP, UDP, IP, ICMP, ARP, DHCP, HTTP, FTP, SMTP, SNMP, Modbus, and MV dedicated protocol  
 E-mail transmission functions (E-mail client):  
 Automatically sends an e-mail in response to alarms and other events.  
 FTP client functions:  
 Automatically sends data files to a FTP server  
 FTP server functions:  
 Can transfer and delete files, manipulate directories, and produce file lists remotely from a network computer.  
 Web server function:  
 Displays MV screen images on a Web browser.  
 SNMP client function:  
 Queries a set SNMP server for the time and synchronizes with it.  
 SNMP server function:  
 Transmits the MV time settings via SNMP protocol.  
 DHCP client function:  
 Automatically retrieves the network address settings from a DHCP server.

Modbus client function:  
 Loads data from other devices using Modbus protocol.\*  
 \* The calculation option (/M1) or the external input channel option (/MC1) is required to load data.

Modbus server function:  
 Data can be read from the MV using the Modbus protocol.

**USB interface**

USB interface:  
 USB specification 1.1 host  
 Ports: 2 (front and back)  
 Connectable devices:  
 Keyboards: 104 keyboards (US) compliant with USB HID Class Version 1.1  
 External media:  
 USB flash drive (not all types of USB memory are guaranteed to work)

**Power supply**

AC power supply:  
 Rated supply voltage:  
 100 to 264 VAC (auto switching)  
 Operating supply voltage range:  
 90 to 132, 180 to 264 VAC  
 DC power supply:  
 Rated supply voltage:  
 12 VDC/24 VDC  
 Operating supply voltage range:  
 10.0 to 28.8 VDC

**Power consumption**

**MV1000 power consumption**

Supply voltage	LCD off	Normal	Maximum
100 VAC	15 VA	30 VA	45 VA
240 VAC	25 VA	40 VA	60 VA
12 VDC	7 VA	14 VA	24 VA

**MV2000 power consumption**

Supply voltage	LCD off	Normal	Maximum
100 VAC	28 VA	40 VA	65 VA
240 VAC	38 VA	54 VA	90 VA
12 VDC	9 VA	18 VA	35 VA

Rechargeable battery drive (supply voltage suffix code -3)

Powered by the dedicated AC adapter or the dedicated Ni-MH battery pack.

- The dedicated Ni-MH battery pack can only be charged when installed in the main unit.
- If both the AC adapter and battery pack are connected, the AC adapter will be used.

Under Ni-MH battery drive:  
 Dedicated Ni-MH Battery Pack:  
 3500 mAh, 13.2 V  
 Number of recharges (cycle life) – Approximately 300 (depends on operating conditions)

Charging function:  
 With either the dedicated battery pack or dedicated AC adapter connected  
 The quick-charge mode can be started whether the power switch is turned ON or OFF. Charging time is approximately 2.5 hours.

Continuous operation time:  
 Refer to the following table for the reference values at room temperature.

	Operating conditions	MV1012	MV1004	MV1008/1024
Minimum power During consumption	USB disconnected, no option terminals LCD Brightness: Backlight saver ON*1 External media saving: Auto-save ON	13 h	10 h	9 h
Normal power During consumption	USB disconnected, no option terminals LCD Brightness: Default value 2*2 External media saving: Auto-save ON	9 h	8 h	7 h
Minimum power During consumption	USB disconnected, with option terminals LCD Brightness: Maximum value 8 External media saving: Auto-save ON (no option terminals)	4 h	4 h	5 h

Note: The continuous operation time varies depending on the operating conditions of the main unit settings (LCD brightness, external media saving) and the main unit specifications (with or without options, etc.).

\*1: Backlight saver mode: OFF, backlight saver transition time: 1 min  
 \*2: Factory setting

**Power consumption:**

Maximum 14 VA with battery output  
 Other: AUTO (auto switching) of A/D integral time is set to 20 ms.  
 Display: Alarm LED – Lights when battery voltage drops  
 Charge LED – Lights/blinks depending on the charging status

**Using the AC adapter**

Rated supply voltage: 100 to 240 VAC  
 Allowable supply voltage range: 90 to 264 VAC  
 Rated supply frequency: 50/60 Hz  
 Allowable frequency range: 48 to 62 Hz  
 Rated AC adapter output voltage: 19.5 V  
 (18.0 V to 20.0 V)

AC adapter rated maximum output current:  
 : 4.7 A

Maximum input power consumption:  
 125 VA

**Power consumption:**

Supply Voltage	Minimum Consumption	Normal Consumption	Maximum Consumption
100 VAC	105 VA	105 VA	115 VA
240 VAC	105 VA	115 VA	125 VA

**Other Specifications**

**Dielectric strength:**

Power supply to ground terminal (100 VAC/240 VAC):  
 2300 VAC (50/60 Hz), 1 min

Power supply to ground terminal (12 VDC):  
 500 VAC (50/60 Hz), 1 min

Contact output terminal to ground terminal:  
 1600 VAC (50/60 Hz), 1 min

Measuring input terminal to ground terminal:  
 1500 VAC (50/60 Hz), 1 min

Between measuring input terminals:  
 1000 VAC (50/60 Hz), 1 min

(except for b-terminal of RTD input of MV1006, MV1012, MV1024, MV2010, MV2020, MV2030, MV2040 and MV2048)

Between remote control terminal to ground terminal:  
 1000 VDC, 1 min

Between pulse input terminal to ground terminal:  
 1000 VDC, 1 min

Dedicated AC adapter power supply line to earth:  
 1500 VAC (50/60 Hz), for one minute  
 (Main unit 12 V power input terminal to ground: 12 VDC model 500 VAC, 1 min., battery model non-isolated)

Other: AUTO (auto switching) of A/D integral time is set to 20 ms.

**Safety and EMC Standards**

- CSA: CSA22.2 No1010.1  
Installation category II<sup>\*1</sup>, pollution degree 2<sup>\*2</sup>
- UL: UL61010B-1 (CSA NRTL/C)
- CE: EMC directive:
  - EN61326 compliance  
(Emission: Class A, Immunity:  
Annex A)
  - EN61000-3-2 compliant
  - EN61000-3-3 compliant
  - EN55011 compliant
- Low voltage directive:
  - EN61010-1 compliant, measure-  
ment category II<sup>\*3</sup>, pollution degree  
2<sup>\*2</sup>
- C-Tick: AS/NZS CISPR11 compliant, Class A Group  
1

\*1: Installation Category (Overvoltage Category) II  
Describes a number which defines a transient overvoltage condition. It implies the regulation for impulse withstand voltage. "II" applies to electrical equipment which is supplied from fixed installations like distribution boards.

\*2: Pollution Degree  
Describes the degree to which a solid, liquid, or gas which deteriorates dielectric strength or surface resistivity is adhering. "2" applies to normal indoor atmosphere. Normally, only non-conductive pollution occurs.

\*3: Measurement Category II  
Applies to measuring circuits connected to low voltage installation, and electrical instruments supplied with power from fixed equipment such as electric switchboards.

**Normal operating conditions**

- Supply voltage:
  - AC power supply:  
90 to 132, 180 to 250 VAC
  - DC power supply:  
10.0 to 28.8 VDC
- Supply frequency:  
50 Hz±2%, 60 Hz±2%
- Ambient temperature:  
0 to 40°C (Battery model: 10 to 40°C)
- Ambient humidity:  
20 to 80% RH (at 5 to 40°C)

**Standard Performance**

Measuring Accuracy:

The following specifications apply to operation of the recorder under standard operation conditions.

Temperature:

23 ±2 °C

Humidity: 55%±10% RH

Power supply voltage:

90 to 132 or 180 to 250 VAC

Power supply frequency:

50/60 Hz ±1%

Warm-up time:

At least 30 min.

Other ambient conditions such as vibration should not adversely affect recorder operation.

Input	Range	Measurement accuracy (digital display)		Max. resolution of digital display	
		A/D integration time: 16.7 ms or more	A/D integration time: 1.67 ms		
DCV	20 mV	±(0.05% of rdg + 12 digits)	±(0.1% of rdg + 40 digits)	1 µV	
	60 mV	±(0.05% of rdg + 3 digits)	±(0.1% of rdg + 15 digits)	10 µV	
	200 mV			10 µV	
	2 V			100 µV	
	6 V	±(0.05% of rdg + 3 digits)	±(0.1% of rdg + 15 digits)	1 mV	
	1-5 V			1 mV	
	20 V			1 mV	
	50 V			10 mV	
10 mV					
TC (Excluding RJC accuracy and burn out: off)	R	±(0.15% of rdg + 1°C) However, R, S: ±3.7°C at 0 to 100°C ±1.5°C at 100 to 300°C ±2°C at 400 to 600°C Accuracy at less than 400°C is not guaranteed.	±(0.2% of rdg + 4°C) However, R, S: ±10°C at 0 to 100°C ±5°C at 100 to 300°C ±7°C at 400 to 600°C Accuracy at less than 400°C is not guaranteed.	0.1°C	
	S	±(0.15% of rdg + 0.7°C) However, ±(0.15% of rdg + 1°C) at -200 to -100°C	±(0.2% of rdg + 3.5°C) However, ±(0.15% of rdg + 6°C) at -200 to -100°C		
	B				±(0.2% of rdg + 2.5°C) However, ±(0.2% of rdg + 5°C) at -200 to -100°C
	K				
	E				
	J				
	T				
	L				
	U				
	N	±(0.15% of rdg + 0.7°C)	±(0.3% of rdg + 3.5°C)		
W	±(0.15% of rdg + 1°C)	±(0.3% of rdg + 7°C)			
WRe	±(0.2% of rdg + 2.5°C) However, ±4°C at 0 to 200°C	±(0.3% of rdg + 10°C) However, ±18°C at 0 to 200°C			
RTD*3	Pt100	±(0.15% of rdg + 0.3°C)	±(0.3% of rdg + 1.5°C)		
	JPt100				
DI	DCV	Threshold level (Vth=2.4 V) accuracy ±0.1 V <sup>*1</sup>			
	Contact	Less than 1 kΩ: 1 (ON), 100 kΩ or more: 0 (OFF) (Parallel capacity: Less than 0.01 µF) *2			

\*1 Measured at 6 V range.

\*2 Measured at 200 mV range with measuring current approx. 10 µA. Threshold level is approx. 0.1 V.

\*3 Measured at 600 mV range with measuring current: i=1 mA.

Measurement accuracy in case of scaling (digits):

= measurement accuracy (digits) x scaling span (digits)/measurement span (digits) + 2 digits

Decimals are rounded off to the next highest number.

Reference junction compensation accuracy:

Types R, S, W, WRe: ±1 °C  
Types K, J, E, T, N, L, U: ±0.5 °C  
Types B: Internal RJC is fixed to 0 °C (Above 0 °C, input terminal temperature is balanced)

Maximum allowable input voltage:

±60 VDC (continuous) for all input ranges

Input resistance:

Approx. 10 MΩ or more for DCV ranges of 200 mVDC or less and TC  
Approx. 1 MΩ for more than 2 VDC ranges

Input source resistance:

DCV, TC: 2 kΩ or less

RTD(Pt100):

10 Ω or less per wire (The resistance of all three wires must be equal.)

Input bias current:

10 nA or less (approx. 100 nA for TC range with burnout function)

Maximum common mode noise voltage :

250 Vrms AC (50/60 Hz)

Maximum noise voltage between channels:

250 Vrms AC (50/60 Hz)

Interference between channels:

120 dB

(when the input source resistance is 500 Ω and the inputs to other channels are 60 V)

Common mode rejection ratio:  
 A/D integration time 20 ms:  
     More than 120 dB (50 Hz±0.1%, 500 Ω imbalance between the minus terminal and ground)  
 A/D integration time 16.7 ms:  
     More than 120 dB (60 Hz±0.1%, 500 Ω imbalance between the minus terminal and ground)  
 A/D integration time 1.67 ms:  
     More than 80 dB (50/60 Hz±0.1%, 500 Ω imbalance between the minus terminal and ground)  
 Normal mode rejection ratio:  
 A/D integration time 20 ms:  
     More than 40 dB (50 Hz ±0.1%)  
 A/D integration time 16.7 ms:  
     More than 40 dB (60 Hz ±0.1%)  
 A/D integration time 1.67 ms:  
     50/60 Hz is not rejected.

Statistical calculations:  
     TLOG (maximum value, minimum value, average value, integrated value, and P-P value for time series data)  
     CLOG (maximum value, minimum value, average value, integrated value, and P-P value for a set channel)  
 Special calculations:  
     PRE, HOLD(a):b, RESET(a):b, CARRY(a):b  
 Conditional statement:  
     [a?b:c]  
 Constants: 60 (K01 to K60)  
 Report function:  
     Report types:  
         Hourly, daily, hourly + daily, daily + weekly, daily + monthly  
 Calculation types:  
     Reports can be calculated using a combination of up to four of the following: Average, maximum value, minimum value, integrated value, and instantaneous value.

**Optional specifications**

**Alarm output relays (/A1, /A2, /A3, /A4\*)**

Output points:  
     Choose from 2, 4, 6, or 12\*  
     \*Only with the MV2000

**Serial communication (/C2, /C3)**

Media: EIA RS-232 (/C2) and RS-422/485 (four-wire) (/C3) compatible  
 Protocols: The dedicated protocol and the Modbus (master/slave) protocol  
 Settings/measurement server functions:  
     Using the dedicated protocol, the following functions are available  
     -Settings and commands equivalent to the unit's key commands.  
     -Data output  
 Modbus master/slave functions:  
     Loads data from other devices using Modbus protocol.\*  
     \*The calculation option (/M1) or the external input channel option (/MC1) is required to load data.

**Fail/status output relay (/F1)**

Activates a relay output upon the detection of a CPU abnormality on the MV or a set condition.

**Mathematical functions (/M1)**

Performs calculations as well as displays and records the trends or numeric values of calculation channels listed below.  
 Max. Calculation channels :  
     MV1004, MV1008:  
         12 channels  
     MV1006, MV1012, MV1024:  
         24 channels  
     MV2008 : 12 channels  
     MV2010, MV2020, MV2030, MV2040, MV2048 :  
         60 channels  
 Max. equation length:  
     120 characters  
 Calculation types:  
     General calculations:  
         Basic arithmetic, square root, absolute value, common logarithm, natural logarithm, exponent, power, relational operations (<, ≦, >, ≧, =, ≠), logical operations (AND, OR, NOT, XOR)

**Cu10/Cu25 RTD input/3-wire isolated RTD input (N1)**

Enables the use of Cu10 and Cu25 inputs in addition to the standard inputs.

Measuring Accuracy:

The following specifications apply to operation of the recorder under standard operation conditions.

Temperature:  $23 \pm 2 \text{ }^\circ\text{C}$

Humidity:  $55\% \pm 10\% \text{ RH}$

Power supply voltage:

90 to 132 or 180 to 250 VAC

Power supply frequency:

50/60 Hz  $\pm 1\%$

Warm-up time:

At least 30 min.

Other ambient conditions such as vibration should not adversely affect recorder operation.

Input	Type	Measure- ment range	Accuracy guaranteed range	Measurement accuracy		Max. resolution of digital display
				A/D integration time: 16.7 ms or more	A/D integration time: 1.67 ms	
RTD*1	Cu1 (Cu10 (GE))	-200 to 300°C	-70 to 170°C	$\pm(0.4\% \text{ of rdg} + 1.0^\circ\text{C})$	$\pm(0.8\% \text{ of rdg} + 5.0^\circ\text{C})$	0.1°C
	Cu2 (Cu10 (L&N))		-75 to 150°C			
	Cu3 (Cu10 (WEED))		-200 to 260°C			
	Cu4 (Cu10 (BAILEY))		-200 to 300°C			
	Cu5 (Cu10 :a=0.00392 at 20°C)					
	Cu6 (Cu10 :a=0.00393 at 20°C)					
	Cu25 (Cu25 :a=0.00425 at 0°C)					

\*1 Measured at 200 mV range with measuring current:  $i=1 \text{ mA}$

**3-wire isolated RTD input (N2)**

All RTD (resistance thermometer detector) terminals (A, B, and b) are isolated.

Note: Only available with the MV1006, MV1012, MV1024, MV2010, MV2020, MV2030, MV2040, and MV2048

**Extended input types (/N3)**

Enables the use of the following thermocouples and RTDs in addition to the standard inputs.

TC : Kp vs Au7Fe, PLATINEL, PR40-20, NiNiMo, W/Wre26, TypeN (AWG14)

RTD: Pt25, Pt50, Ni100(SAMA), Ni100(DIN), Ni120, J263\*B, Cu53, Cu100

Measuring Accuracy:

The following specifications apply to operation of the recorder under standard operation conditions.

Temperature:

23 ± 2 °C

Humidity: 55% ± 10% RH

Power supply voltage:

90 to 132 or 180 to 250 VAC

Power supply frequency:

50/60 Hz ± 1%

Warm-up time:

At least 30 min.

Other ambient conditions such as vibration should not adversely affect recorder operation.

Input	Type	Measurement range	Measurement accuracy		Max. resolution of digital display
			A/D integration time: 16.7 ms or more	A/D integration time: 1.67 ms	
TC	Kp (Kp vs Au7Fe)	0.0 to 300.0 K	Within ±4.5 K at 0 to 20 K Within ±2.5 K at 20 to 300 K	Within ±13.5 K at 0 to 20 K Within ±7.5 K at 20 to 300 K	0.1 K
	PLATI (PLATINEL)	0.0 to 1400.0°C	±(0.25% of rdg+2.3°C)	±(0.25% of rdg+8.0°C)	0.1°C
	PR (PR40-20)	0.0 to 1900.0°C	Accuracy is not guaranteed at 0 to 450°C ±(0.9% of rdg+3.2°C) at 450 to 750°C ±(0.9% of rdg+1.3°C) at 750 to 1100°C ±(0.9% of rdg+0.4°C) at 1100 to 1900°C	Accuracy is not guaranteed at 0 to 450°C ±(0.9% of rdg+15.0°C) at 450 to 750°C ±(0.9% of rdg+6.0°C) at 750 to 1100°C ±(0.9% of rdg+3.0°C) at 1100 to 1900°C	
	NiMo (NiNiMo)	0.0 to 1310.0°C	±(0.25% of rdg+0.7°C)	±(0.5% of rdg+3.5°C)	
	W/WRe (W/WRe26)	0.0 to 2400.0°C	±15.0°C at 0 to 400°C ±(0.2% of rdg+2.0°C) at 400 to 2400°C	±30.0°C at 0 to 400°C ±(0.4% of rdg+4.0°C) at 400 to 2400°C	
	N2 (TypeN (AWG14))	0.0 to 1300.0°C	±(0.2% of rdg+1.3°C)	±(0.5% of rdg+7.0°C)	
RTD*1	Pt50 (Pt50)	-200.0 to 550.0°C	±(0.3% of rdg+0.6°C)	±(0.6% of rdg+3.0°C)	0.1 K
	Ni1 (Ni100(SAMA))	-200.0 to 250.0°C	±(0.15% of rdg+0.4°C)	±(0.3% of rdg+2.0°C)	
	Ni2 (Ni100(DIN))	-60.0 to 180.0°C	±(0.15% of rdg+0.4°C)	±(0.3% of rdg+2.0°C)	
	Ni3 (Ni120)	-70.0 to 200.0°C	±(0.15% of rdg+0.4°C)	±(0.3% of rdg+2.0°C)	
	J263 (J263*B)	0.0 to 300.0 K	Within ±3.0 K at 0 to 40 K Within ±1.0 K at 40 to 300 K	Within ±9.0 K at 0 to 40 K Within ±3.0 K at 40 to 300 K	
	Cu53 (Cu53)	-50.0 to 150.0°C	±(0.15% of rdg+0.8°C)	±(0.3% of rdg+4.0°C)	0.1°C
	Cu100 (Cu100)	-50.0 to 150.0°C	±(0.2% of rdg+1.0°C)	±(0.4% of rdg+5.0°C)	
	Pt25 (Pt25)	-200.0 to 550.0°C	±(0.15% of rdg+0.6°C)	±(0.3% of rdg+3.0°C)	

\*1 Measured at 200 mV range with measuring current: i=1 mA. Measured at 600 mV range in case of Ni1, Ni2 and Ni3.

**Remote control (/R1)**

The MV can be controlled through contact input (up to 8 inputs can be set).

**24 VDC transmitter power supply (/TPS2\*, /TPS4\*)**

Output voltage:

22.8 to 25.2 VDC (for rated current load)

Rated output current:

4 to 20 mADC

Maximum output current:

25 mADC (overcurrent protection level: approximately 68 mADC)

\*/TPS2 is only available for the MV1000, /TPS4 is only available for the MV 2000

**Pulse input (/PM1)**

Contact and open-collector pulse input is possible through the use of special remote input terminals.

The calculation functions (/M1) and remote control (R1) options are included in the pulse input option.

Number of inputs:

3 channels (however, if the remote control input terminals are used for pulse input, then up to 8 channels can be made available)

Input type/Signal level:  
 Non-voltage contact:  
 Close: 200 Ω or less, Open: 100 kΩ or more  
 Open collector:  
     ON: 0.5 V or less (30 mADC), Leakage  
     current of OFF: 0.25 mA or less  
 Allowable input voltage:  
     30 VDC  
 Max. sampling pulse period:  
     Max. 100 Hz  
 Minimum pulse length:  
     5 ms for low (close) and high (open)  
 Pulse detection period:  
     Approx. 3.9 ms (256 Hz)  
 Pulse measuring accuracy:  
     ±1 pulse (for instantaneous mode)

**Calibration correction function (/CC1)**

Corrects the measurement value of each channel using  
 segment linearizer approximation.  
 Settable segment points:  
     2 to 16

**External input function (/MC1, only available on the MV2000)**

You can use the Modbus master function to load data  
 from other devices, and set data through the use of  
 communication input commands. Additional channels  
 are provided for communication input.  
 Note 1: Only available with the MV2010, MV2020, MV2030,  
 MV2040, and MV2048  
 Note 2: When equipped with the external input channel  
 option, the fast sampling mode measurement  
 interval is unavailable.  
 Number of external input channels:  
     240 channels (channel numbers 201 to 440)

**APPLICATION SOFTWARE**

**DAQSTANDARD (DXA120)**

Operating environment  
 OS: Microsoft Windows 2000/XP/Vista\*  
     \*Home Premium and Business (except for 64  
     bits version)  
 Processor: Pentium 4 3 GHz or higher  
 Memory: 2 GB or more  
 Hard disk: Free area of at least 100 MB  
 Display card:  
     Compatible with Windows 2000/XP/Vista  
 Configuration software:  
 Setting mode:  
     Configuration of setting mode and basic  
     setting mode  
 Configuration via communication:  
     Configuration of setting mode and basic  
     setting mode without communication  
     configuration (ex. IP address)  
 Data viewer software:  
 Number of display channels:  
     32 channels per group, 50 groups  
     maximum  
 Viewer function  
     Waveform display, digital display, circular  
     display, list display, report display etc.  
 Data conversion:  
     File conversion to ASCII, Lotus 1-2-3 or  
     MS-Excel format

**MODEL AND SUFFIX CODES**

**MV1000**

Model code	Suffix code	Optional code	Description
MV1004			4 ch, 125 ms (Fast sampling mode: 25 ms)
MV1006			6 ch, 1 s (Fast sampling mode: 125 ms)
MV1008 <sup>*9</sup>			8 ch, 125 ms (Fast sampling mode: 25 ms)
MV1012			12 ch, 1 s (Fast sampling mode: 125 ms)
MV1024 <sup>*9</sup>			24 ch, 1 s (Fast sampling mode: 125 ms)
Internal Memory	-3		400 MB
External Media	-4		CF card (with Media)+USB
Language	-2		English/German/French
	-4		Korean
Input Terminal	-1		Clamped terminal
	-2		Screw terminal (M4)
Power Supply	-1		100 VAC, 240 VAC
	-2		12 VDC <sup>*1</sup>
	-3		Rechargeable battery <sup>*1</sup>
Power Cord	D		Power cord UL/CSA Standard
	F		Power cord VDE Standard
	R		Power cord SAA Standard
	Q		Power cord BS/PSB Standard <sup>*11</sup>
	H		Power cord GB Standard
	P		Power cord EK Standard <sup>*10</sup>
	W		without AC adapter, Power cord <sup>*2</sup>
Options	/A1		Alarm output 2 points <sup>*3*9</sup>
	/A2		Alarm output 4 points <sup>*3*9</sup>
	/A3		Alarm output 6 points <sup>*3*4*9</sup>
	/C2		RS-232 interface <sup>*5</sup>
	/C3		RS-422/485 interface <sup>*5</sup>
	/F1		FAIL/Status output <sup>*4*9</sup>
	/M1		Mathematical functions
	/N1		Cu10,Cu25 RTD input /3 leg isolated RTD
	/N2		3 leg isolated RTD <sup>*6</sup>
	/N3		Extended input type (PR40-20,Pt50, etc.)
	/R1		Remote control <sup>*9</sup>
	/TPS2		24 VDC transmitter power supply (2 loops) <sup>*7*9</sup>
	/PM1		Pulse input (including remote control and mathematical functions) <sup>*8*9</sup>
/CC1		Calibration correction function	

- \*1 An AC adapter is included as a standard accessory.
- \*2 W can be specified for only 12 VDC
- \*3 /A1, /A2 and /A3 cannot be specified together.
- \*4 /A3 and /F1 cannot be specified together.
- \*5 /C2 and /C3 cannot be specified together.
- \*6 /N2 can be specified for only MV1006, MV1012 and MV1024.
- \*7 In case that /TPS2 is specified, /A2, /A3, /F1 and /PM1 cannot be specified together.
- \*8 In case that /PM1 is specified, /A3, /M1, /R1 and /TPS2 cannot be specified together.  
And combination of /A2/F1 cannot be specified together.
- \*9 In case that MV1008, MV1024 is specified, /A1, /A2, /A3, /F1, /R1, /TPS2 and /PM1 cannot be specified.
- \*10 In case that 100 VAC, 240 VAC is specified, P cannot be specified together.
- \*11 BS standard is specified only 100 VAC, 240 VAC

**MV2000**

Model code	Suffix code	Optional code	Description
MV2008			8 ch, 125 ms (Fast sampling mode: 25 ms)
MV2010			10 ch, 1 s (Fast sampling mode: 125 ms)
MV2020			20 ch, 1 s (Fast sampling mode: 125 ms)
MV2030			30 ch, 1 s (Fast sampling mode: 125 ms)
MV2040			40 ch, 1 s (Fast sampling mode: 125 ms)
MV2048			48 ch, 1 s (Fast sampling mode: 125 ms)
Internal Memory	-3		400 MB
External Media	-4		CF card (with Media)+USB
Display language	-2		English/German/French
	-4		Korean
Input Terminal	-1		Clamped terminal
	-2		Screw terminal (M4)
Power Supply	-1		100 VAC, 240 VAC
	-2		12 VDC *1
Power Code		D	Power cord UL/CSA Standard
		F	Power cord VDE Standard
		R	Power cord SAA Standard
		Q	Power cord BS/PSB Standard *11
		H	Power cord GB Standard
		P	Power cord EK Standard *10
		W	without AC adapter, Power cord *2
Options		/A1	Alarm output 2 points *3
		/A2	Alarm output 4 points *3
		/A3	Alarm output 6 points *3
		/A4	Alarm output 12 points *3,4
		/C2	RS-232 interface *5
		/C3	RS-422/485 interface *5
		/F1	FAIL/Status output *4
		/M1	Mathematical function
		/N1	Cu10,Cu25 RTD input /3 leg isolated RTD
		/N2	3 leg isolated RTD *6
		/N3	Extended input type (PR40-20,Pt50, etc.)
		/R1	Remote control
		/TPS4	24 VDC transmitter power supply (4 loops) *7
		/PM1	Pulse input (including remote control and mathematical functions) *8
		/CC1	Calibration correction function
		/MC1	External input function *9

- \*1 An AC adapter is included as a standard accessory.
- \*2 W can be specified for only 12 VDC
- \*3 /A1, /A2, /A3 and /A4 cannot be specified together.
- \*4 /A4 and /F1 cannot be specified together.
- \*5 /C2 and /C3 cannot be specified together.
- \*6 /N2 can be specified for only MV2010, MV2020, MV2030, MV2040 and MV2048.
- \*7 In case that /TPS4 is specified, /A4 cannot be specified together.  
And combination of /A3/F1 cannot be specified together.
- \*8 In case that /PM1 is specified, /A4, /M1, /R1 cannot be specified together.  
And combination of /A2/F1 and /A3/TPS4 cannot be specified together.
- \*9 /MC1 can be specified for only MV2010, MV2020, MV2030, MV2040 and MV2048.
- \*10 In case that 100 VAC, 240 VAC is specified, P cannot be specified together.
- \*11 BS standard is specified only 100 VAC, 240 VAC

**DAQSTANDARD**

**DAQSTANDARD**

Model code	Description	OS
DXA120	DAQSTANDARD	Windows 2000, XP, Vista

## STANDARD ACCESSORIES

Product	Qty.
DAQSTANDARD	1
Terminal Screw	5
Instruction manual (First step guide: by paper)	1
Instruction manual (Mainunit/commuication/DAQSTANDARD:CD-ROM)	1
128 MB CF CARD	1
Power cord	1 <sup>*1</sup>
AC adapter + Power cord	1 <sup>*2</sup>

\*1 100 VAC/240 VAC Power supply (When the "-1" Power supply specification code is specified)

\*2 12 VDC Power supply (When specified the "-2" Power supply specification code)  
or Rechargeable battery (When specified the "-3" Power supply specification code)

## OPTIONAL ACCESSORIES

Product	Code (Parts NO.)	Specification
Shunt resister (For screw input terminal)	415920	250Ω±0.1%
	415921	100Ω±0.1%
	415922	10Ω±0.1%
Shunt resister (For clamped input terminal)	438920	250Ω±0.1%
	438921	100Ω±0.1%
	438922	10Ω±0.1%
CF card adapter (not including CFcard)	772090	
CF CARD (not including adapter)	772093	512 MB
	772094	1 GB
Soft carrying case	790501	For MV1000
	701964	For MV2000
Rack mount bracket (JIS)	B8805JU	For MV1000
Rack mount bracket (ANSI)	B8805JT	For MV1000
Rack mount bracket (JIS)	B8806JU	For MV2000
Rack mount bracket (ANSI)	B8806JT	For MV2000
Vertical stand	B8805JL	For MV1000
Battery Pack	B8805HA	Using for Battery model
Removable clamped input terminal	A1923JT	for 2 channels

## DIMENSIONS

### MV1000

Unit : mm  
(approx. inch)

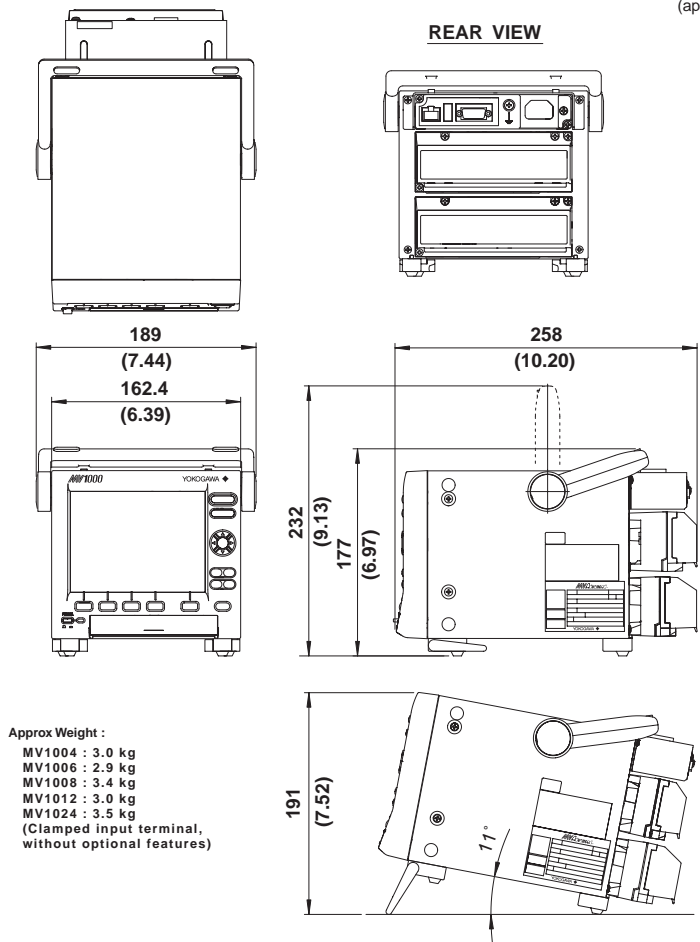

If not specified, the tolerance is  $\pm 3\%$ . However, in cases of less than 10 mm, the tolerance is  $\pm 0.3$  mm.

### MV1000 (Battery Model)

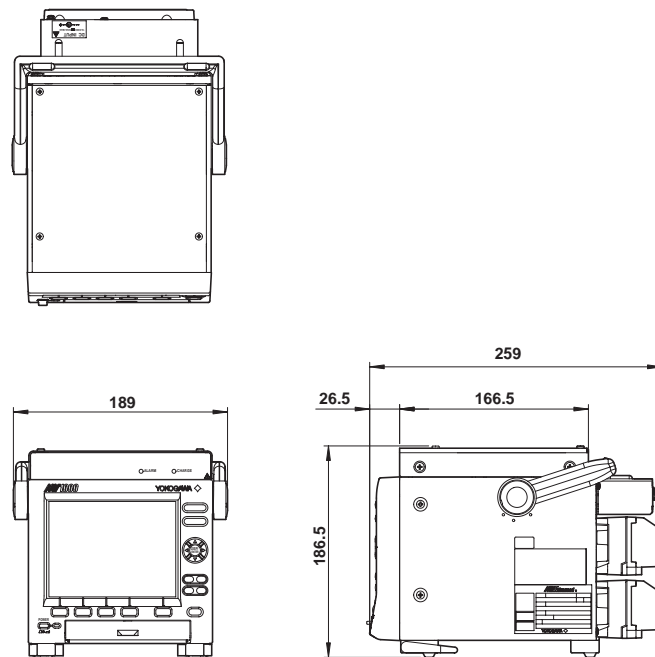

MV2000

Unit : mm  
(approx. inch)

REAR VIEW

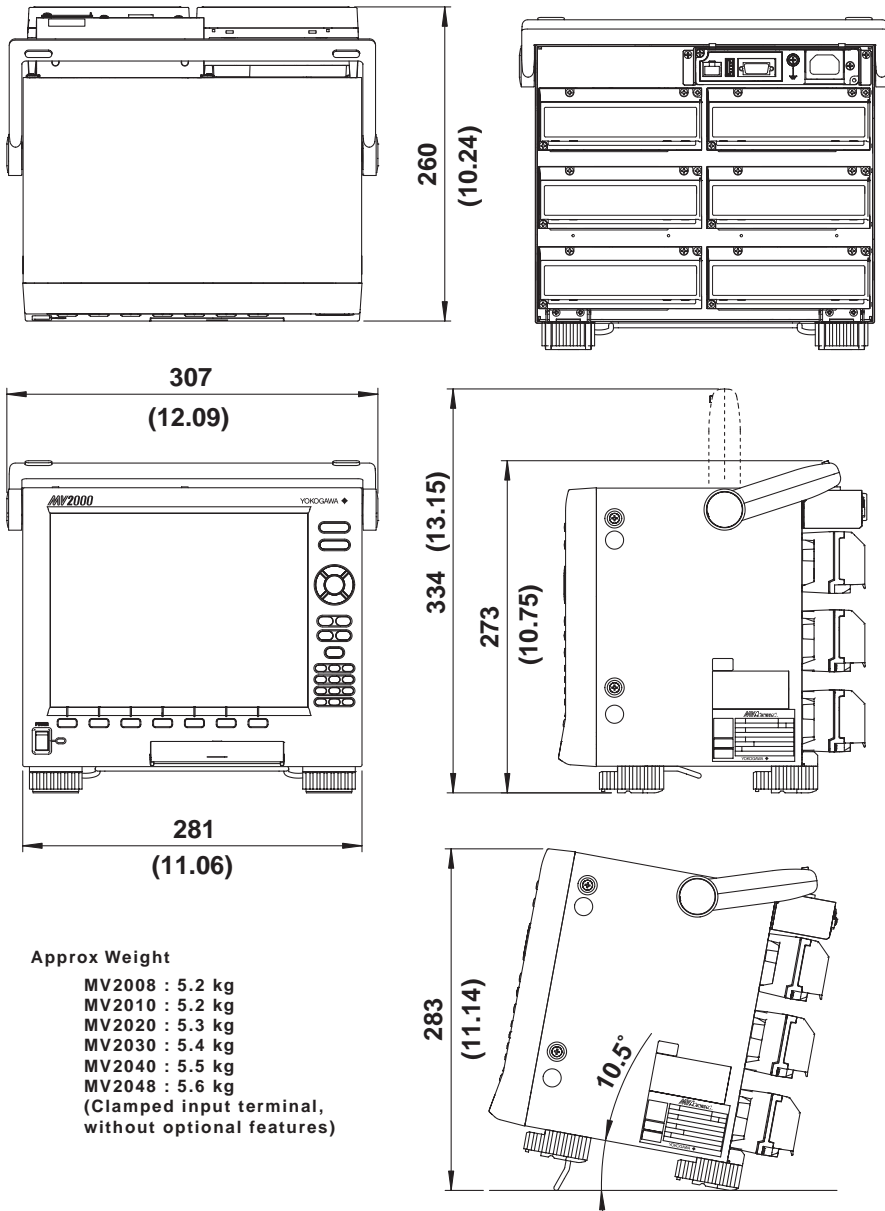

Approx Weight

- MV2008 : 5.2 kg
  - MV2010 : 5.2 kg
  - MV2020 : 5.3 kg
  - MV2030 : 5.4 kg
  - MV2040 : 5.5 kg
  - MV2048 : 5.6 kg
- (Clamped input terminal, without optional features)

If not specified, the tolerance is ±3%. However, in cases of less than 10 mm, the tolerance is ±0.3 mm.

The TCP/IP software used in this product and the document for that TCP/IP software are based in part on BSD networking software, Release 1 licensed from The Regents of the University of California.

- Microsoft, MS and Windows are registered trademarks of Microsoft Corporation USA.
- Lotus and 1-2-3 are registered trademark of Lotus Development Corporation.
- Pentium are registered trademarks of Intel Corporation.
- Ethernet is a registered trademark of XEROX Corporation.
- Modbus is a registered trademark of AEG Schneider.
- Other company and/or product names are registered trade mark of their manufactures.